

Position Control Unit

PS 10-32

9013.0185 / 13.07.2017



1. General Information

The OWIS® PS 10-32 is a single-axis position control unit for basic control functions.

It can control either a 2-phase stepper motor (open loop) up to 1.8A, or DC motors with an encoder (closed loop) up to 3.5A.

The control has an USB interface to communicate with a PC. Many of the inputs and outputs, like TTL, analog inputs and SPS outputs, are integrated for communication.

Point-to-point positioning mode and trapezoidal velocity profiles are possible with the PS 10-32.

Up to 32 units can be combined with this control unit version. Any motor-type combination is possible. The connection is via a rudimentary, simplified CANopen protocol.

Two of the four SPS outputs at the PS 10-32 are configured as PWM to control a holding brake.

The software tool OWISoft is also included, so the PS 10-32 can be configured and controlled easily. The parameters of the positioning units of OWIS® are stored at OWISoft and can be selected to the respective units. Foreign motors can also be controlled.

2. Setup and Scope of Delivery

The PS 10-32 consists of a single unit for different output power classes and motor voltages. The unit is completely assembled and tested by OWIS® and will be supplied ready for installation. The valid firmware for operation is installed.

Following products are also included:

- USB cable, 2 m length
- CD with software tool OWISoft and documentation in English/German
- printed version of the manual in German and English

2.1 Standard

The basic version of the PS 10-32 comes with:

- USB port
- 4 inputs for switches (reference and limit-switches)
- 4 TTL inputs
- 4 analog inputs
- 1 TTL output
- 4 SPS outputs
- connection for enabling the motor output stage
- motor plug D-Sub-37 with additional connections for motor holding brake (option), limit/reference switches and other signals (see pin assignment, p. 50)
- circular connector for power supply from PS 10-32 to PS 10-32
- 2 of the 4 SPS outputs are configured a PWM (e.g. to control a motor holding brake)
- bus interface for cross linking (based on CANopen)

2.2 Accessories

The following accessories are available:

- external desktop power supply AC 100 - 240V, DC 24V, 90W
- connecting cable with plugs for different positioning systems
- connecting cable for bus interface 2 m long
- terminating connectors for bus interface
- connecting cable 2 m long for power supply

3. Safety

The PS 10-32 should only be used by authorized, qualified personnel, and under consideration of the regulations for the prevention of industrial accidents and for the electrical industry. Read the safety instructions (on the data sheet).

Unqualified persons should not operate the position control.

The control unit is designed for an operating temperature range from +10 up to +40 °C, and storage temperature from -10 up to +50 °C.

Protect against high humidity, vibration and explosive gases.

Before opening, the device must be switched off and unplugged.

Connection and installation work should only be done with equipment unpowered. Installation and use of equipment must be in accordance with the standards of the declaration of conformity.

In order to enable the motor output stage jumper JP7 on the control board must be plugged (see 6.4). If the jumper is not plugged, the galvanically separated external release input can be used. For that purpose, the input must be supplied with a voltage of 5 V. If neither the jumper is plugged nor the external voltage is supplied no activating of the output stages is possible.

Furthermore, each type of motor is identified to the motor power stage through a coding resistor. This helps to avoid motor damage if the wrong type of motor has been connected (e.g. a DC motor to a stepper motor output stage).

The respective control unit is only intended to be operated with the preconfigured motor type. Other or related uses are not the intended purpose.

Currents and Voltages

The power input is protected by a 5A slow-blow microfuse.

No special safety precautions are necessary for the outputs, as the PS 10-32 only works with safe, low voltages (PELV) to 24VDC.

The position control unit PS 10-32 is built in accordance with accepted safety rules and satisfies the following standards and directives.

4. Standards and Directives

The position control unit PS 10-32 complies with following standards and regulations:

- RoHS conform
- CE Directive
- EMV Directive 2014/30/EU

Interference immunity, according to the generic standard EN 61000-6-1 with:

- Electrostatic discharge immunity test
Basic standard: EN 61000-4-2 (ESD)
- Radiated, radio-frequency, electromagnetic field immunity test
Basic standard: EN 61000-4-3 (radiated RF)

RF emission, according to the generic standard EN 61000-6-3 with:

- Radiated RF according to
Basic standard: EN 55014-1 (household appliance)

5. Technical Overview

power supply:	external power supply max. 24V, 90W (PS 10-32: connecting cable for power supply)
number of axis:	1 axis (PS 10-32: cross linking up to 32 units)
motor type:	2-phase step motors Open Loop (OL) DC servo motors Closed-Loop (CL)
communication:	USB 2.0
installation:	desktop unit in metal housing
protection class:	IP 20
encoder:	quadrature signals A / B and index, RS-422 or TTL level, with quad evaluation, max. counting frequency 1.875 MHz (signal) respectively 7.5 MHz (quadrature)
functions:	parametrizable acceleration (/ deceleration) ramp, trapezoidal velocity profiles
motion profiles:	point-to-point positioning operation

6. Setup of the Control Unit

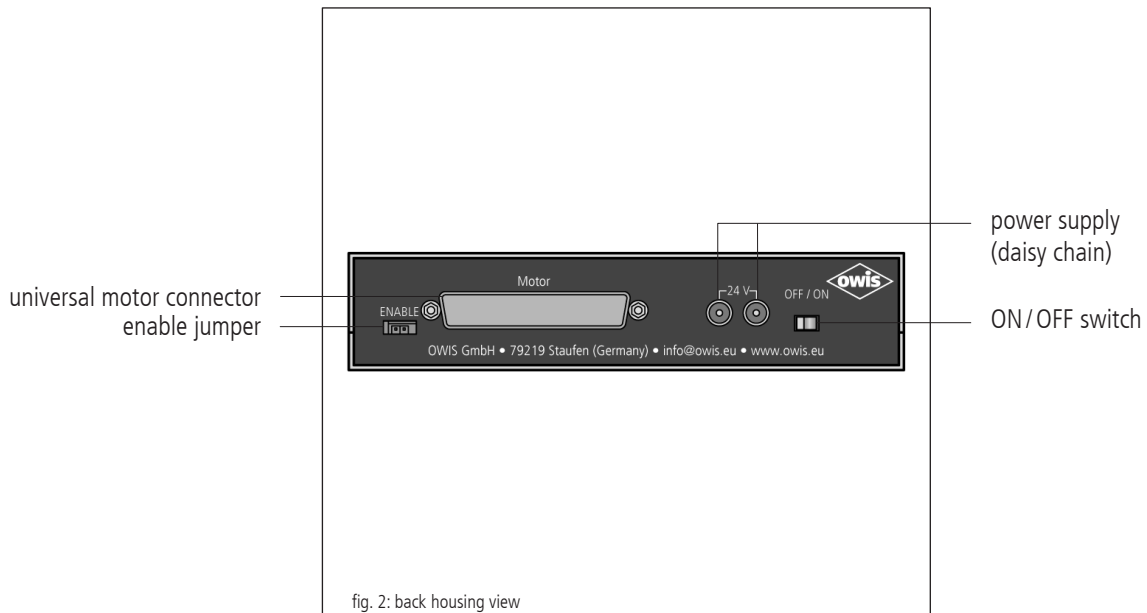
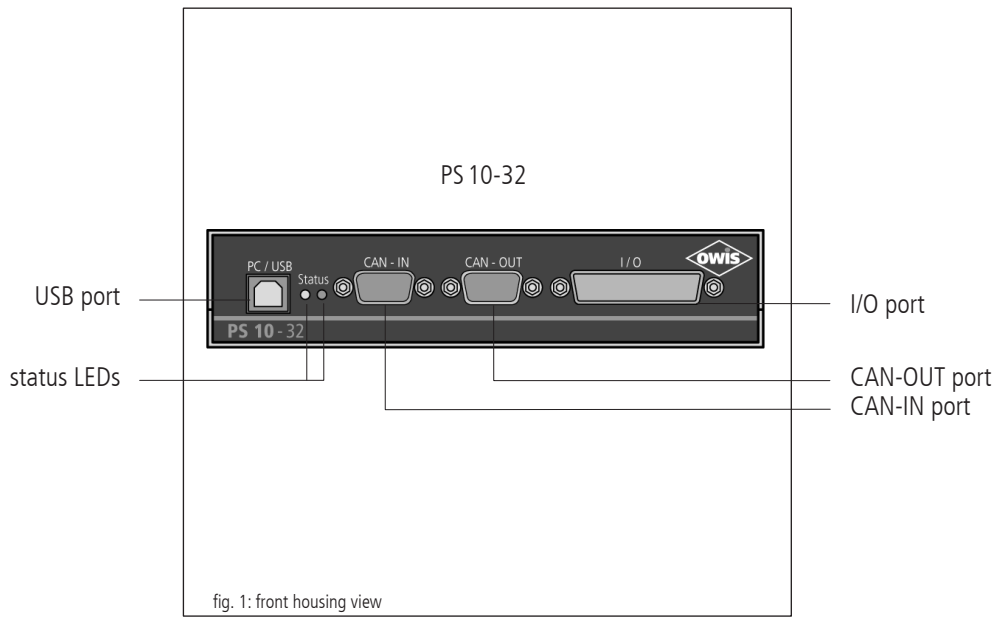

The PS 10-32 is embedded in a robust metal housing.

The waste heat from the control board is emitted to the ambient air.

Status LEDs

The operating state of the control unit is shown by status LEDs at the front side. The displayed states are:

- Power on
- Motor initialised
- Reference valid
- Error

The display signal is given by colours and blinking mode.

Display of the status LEDs

green LED	red LED	description
on		axis is initialized and reference position is valid
off		axis is not initialized
blinking slow 1 Hz		axis is initialized and reference position is invalid
blinking fast 2 Hz		axis drives
	on	no error is set to the axis
	blinking slow 1 Hz	an error is set to the axis

Error can mean: limit switch, break switch, power stage error, time-out error

6.1 Connections

The connections of the PS 10-32 are located on the front and rear side of the housing. These are communication interfaces, inputs and outputs for peripherals as well as connections for the positioning units (see fig. 1 and 2).

connection	function	socket
USB slave	communication with a PC	USB port type B
TTL in-/outputs	interaction with external hardware	D-Sub 25-pole connector
analog inputs	interaction with external hardware	D-Sub 25-pole connector
SPS outputs	interaction with external hardware	D-Sub 25-pole connector
universal motor connector	motor supply with motor holding brake and encoder/limit switch-connection	D-Sub 37-pole connector
24V external/ connecting cable	operating voltage for the motor output stage	DC circular connector 5.5x2.1x11 mm

in Version PS 10-32:

BUS interface (based on CAN)	interaction with further control unit	D-Sub 9-pole connector
------------------------------	---------------------------------------	---------------------------

USB Interface

The PS 10-32 has a USB 2.0 slave-interface. Its connector is placed on the front side of the control unit. The interface is compatible with USB 1.1 and 2.0. The USB interface of the PS 10-32 is implemented as a so-called "COM bridge". The Windows device driver recognizes the PS 10-32 as "USB serial port" and assigns a COM port number to it. This number can be changed by the user, if necessary. After successful installation, the USB interface is addressed as virtual RS-232 interface.

The PS 10-32 can operate with transfer rates of 9 600, 19 200, 38 400, 57 600 or 115 200 baud. Please make sure that the transfer rate of the PS 10-32 corresponds to the transfer rate defined in the device driver, otherwise no communication is possible. Preset is 9 600 baud. (It can be found in the acceptance certificate.)

Universal Motor Connector

The positioning units are connected using the suitable OWIS® connecting cable. The universal motor connector enables the current supply of the motor, control of the motor holding brake, where applicable, and the transfer of the encoder and limit-switch.

The motor power stage contains an additional protection device which helps to avoid motor damage if a wrong motor type has been connected (e.g., a DC motor to a stepper motor output stage). For detection of the motor type, a coding resistor is provided in the 37-pin D-Sub connector of the motor connecting cable between pin 14 and 15.

Coding:

- 0 Ohm: DC servo motor
- infinite resistance (no resistor): 2-phase step motor

When being switched on, the PS 10-32 measures the resistance value and reports an error message, if the measured value does not match the type of the motor power stage. The error message of the output stage can be read out using the command "?ASTAT" (see command set, page 42).

On the motor power stage the universal motor connector is fitted. On this connector, all the necessary signals, such as motor current, limit switches, encoder and holding brake (if any), can be found.

Limit and Reference Switches

Maximum four limit switches per axis can be connected. They can be micro switches, TTL Hall switches or TTL light barriers with +5 V voltage. Various n.c. or n.o. contacts, switching towards GND, can be attached to the inputs.

One of the four switches is defined as reference switch, if necessary.

The active level and the switch assignment are configured by software.

Encoder Input

The encoder input enables both the connection of encoders with line drivers (antivalent signals for CHA, CHB and optionally Index I), and of encoders with TTL/CMOS signals.

The following input signals are defined:

supply voltage	V_{CC} (+5V); GND
channel	A (TTL or CMOS)
channel	A inverted
channel	B (TTL or CMOS)
channel	B inverted
channel	I (TTL or CMOS)
channel	I inverted

The conversion of the antivalent signals to TTL signals takes place with RS-422 receivers. If an encoder with TTL/CMOS signals is connected, then the input for the inverted signal remains open and is internally pulled to 1.4V by a high-impedance voltage divider.

Power Supply

The switch-mode power supply of the PS 10-32 has been designed for an input voltage of 100VAC to 240VAC at 50/60 Hz (wide-range input).

It generates 24VDC, 90W and supplies the outputs and the inputs on the main board.

The supply voltages for logic and motor power are not galvanically separated.

Safety Fuse Concept

There is a separate fuse for the control, rated according to the maximum possible current.

Standard fuse protection of control: 5AT

For the motor power stage an appropriate fuse against high temperatures is embedded.

In Version PS 10-32 Additionally:

BUS Interface

Up to 32 units can be networked with a bus system based on CANopen. The first PS 10-32 is connected to a PC via USB (master), and all other units can be linked among each other (slaves). Commands that are not intended for the master controller are sent on to the subsequent units. The reply of the addressed PS 10-32 will be received from the first control unit (master) and returned via USB to the PC. The master control unit scans the bus, therefore it will be switched on at last.

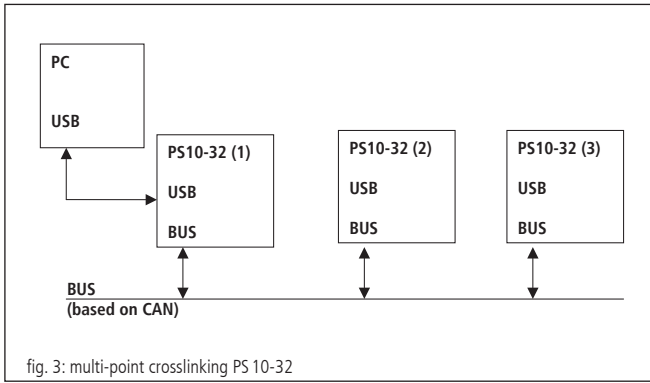

Connection for Power Supply

In principle, several PS 10-32 can be operated by a single external power supply. To loop the supply of a PS 10-32 to the next there are two circular connector ports at the back. Using a connecting cable the power supply is sent to the downstream PS 10-32 units. Thus, the first PS 10-32 is connected to the supply unit and from there power is passed through to the other units. The total current consumption of the positioning units has to be considered. The controller can drive stepper motors up to 1.8A, and DC servo motors up to 3.5A in continuous operation.

Note:
 The maximum capacity of the power supply must not be exceeded!

6.2 In- and Outputs

For interaction with external sensors and actuators, corresponding digital and analog inputs and outputs are provided. Forked light barriers, etc. can be connected to the TTL-compatible inputs. Using the TTL output it is possible to control digital hardware directly in the application setup. The SPS outputs control single solenoid valves or other inductive and resistive loads directly (switching towards +24V).

features	level	current	others
TTL inputs	0-5V		—
Analog inputs	0-5VDC		resolution 10Bit
TTL output	0-5V	10 mA	—
SPS outputs	0-24VDC	0-100 mA	—
power outputs	0-24VDC	1,0A	PWM

The analog inputs can measure voltages between 0V and 5V directly and convert them with a 10-bit resolution (reference voltage: 5V). The inputs are not galvanically separated.

The query commands “?ANIN<uv>” and “?INPUTS” correspond to the same inputs of the PS 10-32 (see command set, page 42). The evaluation of the inputs takes place either analog or digital.

The two power outputs in this control unit are PWM-type and switching towards GND. They are designed to drive inductive loads which need a high actuating current for a short time and a low stand-by current afterwards, such as holding brakes or solenoids.

These power outputs can therefore be configured for driving a motor holding brake.

6.3 Selection of the Current Range for the Motor Power Stage

The PS 10-32 motor power stage has two configurable current ranges in order to obtain high precision in the current value.

After switching on the control unit, the current range selected is stored in the static RAM. In order to activate a new current range, it is necessary to re-initialize the axis <n> after the preset has been done.

Preselection of the current range 1 (low) and 2 (high), respectively for axis <n> takes place after e.g. following command sequence:

```
AMPSHNT<n>= 1
(command to set current range 1 or 2)
```

```
INIT<n>
(command to initialise the axis)
```

Phase Current Setting for 2-Phase Step Motors

Driving and holding current can be separately preset with 2-phase stepper motors. The selection for axis <n> can be done as in the following description. The value <uv> is defined as integer percentage of the maximum current in the pre-selected current range (1 or 2).

```
driving current: DRICUR<n>=<uv>
(command to set the drive current in %)
holding current: HOLCUR<n>=<uv>
(command to set the holding current in %)
current range 1 (corresponding to 100%): 1.2A
current range 2 (corresponding to 100%): 3.3A
```

Note:
 For continuous operation a current of 1.8A is permitted (corresponding to 54 % in current range 2).

In general, the lowest possible current range should be selected, in order to obtain the optimal precision in high-resolution micro step operation.

Current Limiting Setting for DC Servo Motors

The suitable current range for the DC servo motors has to be set in accordance with the thermally admissible continuous current of the corresponding motor type.

```
maximum current limiting: DRICUR<n>=<uv>
(command to set the current limiting in %)
current range 1 (corresponding to 100%): 2.4A
current range 2 (corresponding to 100%): 6.6A
```

Note:
 For continuous operation a current of 3.5A is permitted (corresponding to 54 % in current range 2).

6.4 Control Board Settings

Jumper Settings

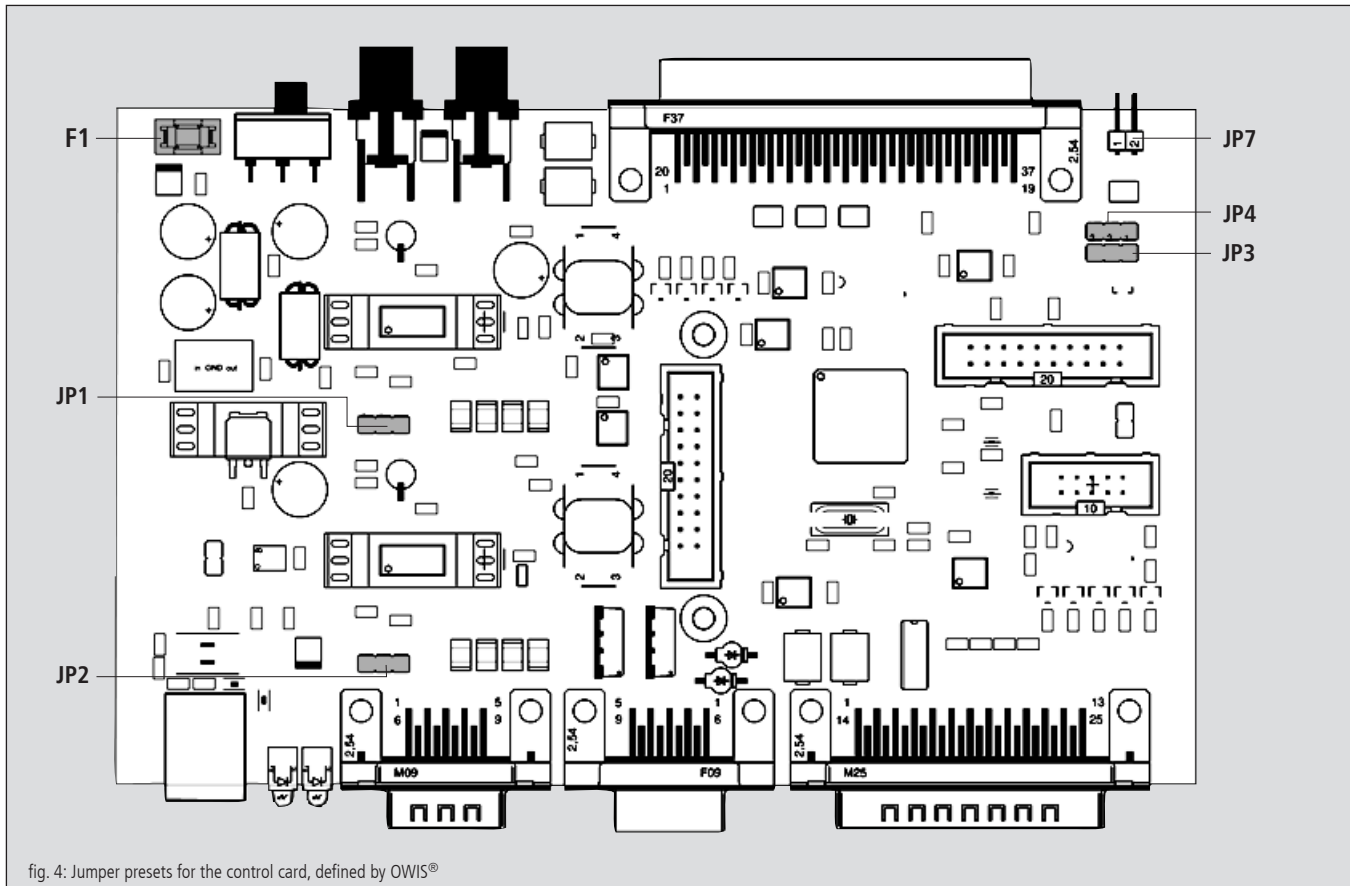

jumper	function	setting possibilities	presetting defined by OWIS®	note
JP1	2-phase step motor resp. DC servo motor	1-2 plugged = 2-phase step motor 2-3 plugged = DC servo motor	plugged suitably	value preset by manufacturer must not be changed
JP2	2-phase step motor resp. DC servo motor	1-2 plugged = 2-phase step motor 2-3 plugged = DC servo motor	plugged suitably	value preset by manufacturer must not be changed
JP3	"Firmware Update" or "Operation" mode	2-3: operation	plugged	value preset by manufacturer must not be changed
JP4	internal use	2-3: normal operation	plugged	value preset by manufacturer must not be changed
JP7	output stage release	jumper plugged = release; jumper open = release with external release input possible	plugged	

F1: 5A slow-blow, for the protection of the external 24V power input for the control unit.

7. Control Functions

7.1 Trapezoidal Point-to-Point Profile

The following table contains the specific profile parameters for the trapezoidal point-to-point mode:

profile parameters	format	word length	range
position	32.0	32 bit	(-2.147.483.648...+2.147.483.647) counts
velocity	32.0	16 bit	(1...2.147.483.647) counts / cycle
acceleration/ deceleration	32.0	16 bit	(1...2.147.483.647) counts / cycle ²

For this profile, the host specifies an initial acceleration and deceleration, a velocity and a destination position. The profile is named after the curve shape (fig. 5): the axis accelerates linearly (on the basis of the programmed acceleration value), until it reaches the programmed speed. Afterwards, the axis slows down linearly (using the deceleration value), until it stops at the defined position. If the programmed travelling distance is so short that deceleration must begin before the axis reaches the programmed velocity, the profile will not have a constant-velocity range, and the trapeze becomes a triangle (fig. 6).

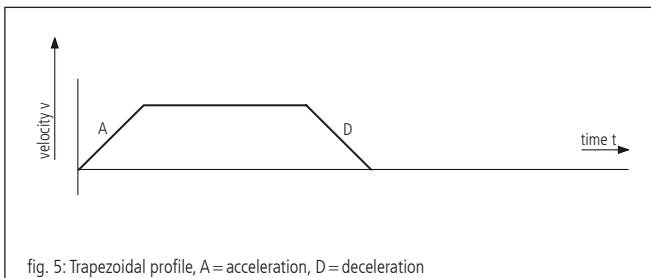

fig. 5: Trapezoidal profile, A = acceleration, D = deceleration

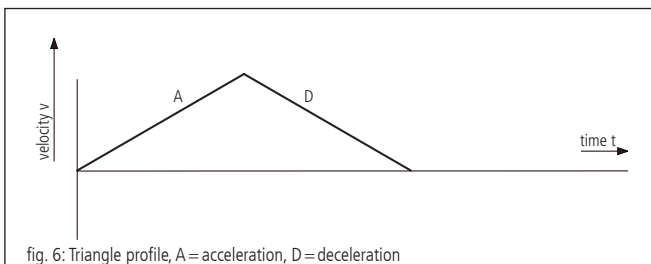

fig. 6: Triangle profile, A = acceleration, D = deceleration

The acceleration and deceleration ramps are symmetric.

The acceleration parameter is always used at the beginning of the movement sequence. Afterwards, the value for acceleration is used in the same direction, and the value for deceleration is used in opposite direction. The acceleration value is used, until the maximum velocity was reached. The deceleration value is used, until the velocity drops to zero.

7.2 Velocity Mode

The following table presents the profile parameters for the velocity mode:

profile parameters	format	word length	range
velocity	32.0	32 bit	(-2.147.483.648...+2.147.483.647) counts / cycle
acceleration/ deceleration	32.0	16 bit	(1...2.147.483.647) counts / cycle ²

Unlike in trapezoidal profiling mode, where the final position determines whether positive or negative speed is defined, it is the sign of the velocity value transmitted within the velocity mode that determines whether the axis moves in positive or negative direction. Therefore, the velocity value sent to the PS 10-32 can take positive values (for positive direction of motion) or negative values (for reverse direction of motion). For this profile no destination position is specified.

The trajectory is executed by continuously accelerating the axis at the specified rate until the corresponding end velocity is reached. The axis begins to slow down, if a new velocity is defined which value is smaller than the current velocity or if it has another sign than indicated by the current direction.

A simple velocity profile looks like a simple trapezoidal point-to-point profile as shown in fig. 7.

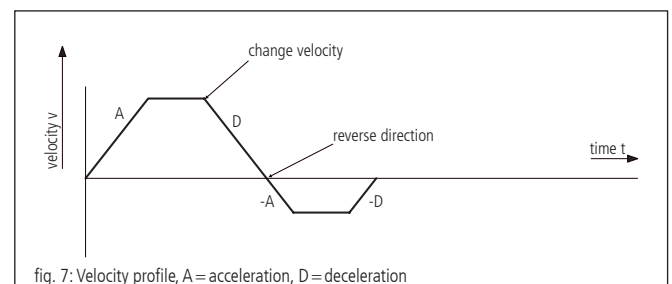

fig. 7: Velocity profile, A = acceleration, D = deceleration

Note:

In the velocity mode, the axis movement is not bound to a final position. It is up to the user to select such velocity and acceleration values which guarantee a safe course of motion.

7.3 Reference run

The reference move drives onto one of the four limit switches. The position can be zeroized at this point. Therefore, two reference driving speeds with amount and sign and a reference acceleration are parameterised. The limit switch is approached with high speed and left with a low, then it is stopped.

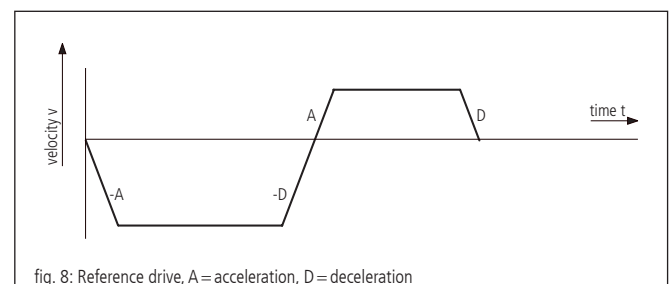

fig. 8: Reference drive, A = acceleration, D = deceleration

8. Travel Measuring

Position Feedback Control

For the operation of DC servo motors an encoder input is included. The signal is used to capture data for the position control loop (PID position control).

Encoder

The travel measuring system, also known as "rotary encoder", for the position feedback signals is evaluated only in the so-called closed-loop operation mode.

Without encoder, only open-loop operation with 2-phase step motors is possible. In order to be able to operate DC motors, each axis must be equipped with a travel measuring system. This can be an encoder. Usually, encoders with 500, 1250 or 2500 lines per revolution are used. The motion processor measures the current axis position via encoder and calculates the appropriate rotational speed of the motor, considering the temporal change of the position parameters.

Encoders are fixed on the motor and directly connected to the rotor. The encoder output signals are named A and B (CHA and CHB) with a phase-shift of 90 degrees (so-called quadrature signals), and, if necessary, one index pulse I per revolution. The PS 10-32 can process TTL level or antivalent signals (line-driver outputs). After a level transformation and a filtering, the signals are transmitted directly to the microprocessor.

Linear Measuring System

A position sensor, directly coupled to the actuator motion, is called linear measuring system. The linear measuring system can be used instead of the encoder for position measuring.

9. PID Servo Loop Algorithm

The servo filter used in the PS 10-32 operates according to a PID algorithm. An integration limit provides an upper bound for the accumulated error.

The PID formula is as follows:

$$\text{output}_n = K_p E_n + K_d (E_n - E_{(n-1)}) + \sum_{j=0}^n E_j \frac{K_i}{256}$$

Meaning of following abbreviations:

- E_n accumulated error terms from the main encoder
- K_i integral gain of feedback control loop
- K_d differential gain of feedback control loop
- K_p proportional gain of feedback control loop

All filter parameters and the torque signal limit are programmable, so that the user is able to fine-tune the filter. The ranges of values and formats are listed in the following table:

terminus	name	range
I_{lim}	integration limit	32 bit unsigned (0...2 124 483 647)
K_i	integral gain	16 bit unsigned (0...32 767)
K_d	derivative gain	16 bit unsigned (0...32 767)
K_p	proportional gain	16 bit unsigned (0...32 767)

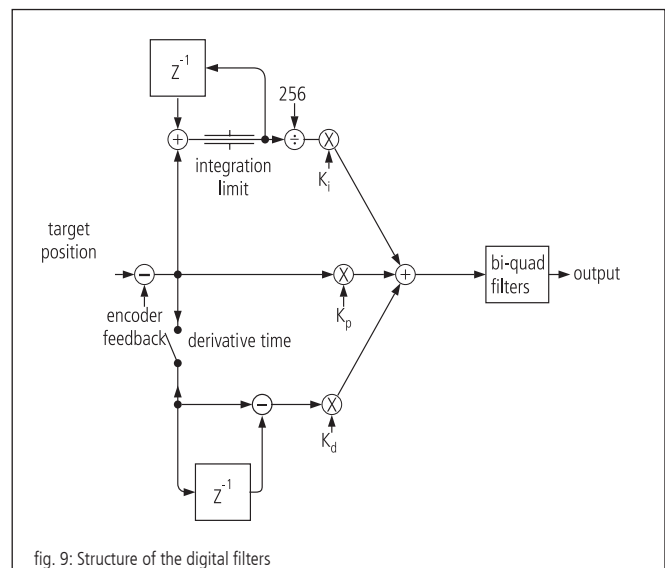

10. Positioning, Velocity and Acceleration, Calculation

10.1 2-Phase Stepper Motor (Open Loop)

General Information

Each stepper-motor-driven system has a so-called start-stop frequency which is especially dependent on motor type, system friction and load (moment of inertia!). The start-stop frequency defines the maximum travel frequency of the stepper motor concerned, with which it starts directly from standstill without acceleration phase. It is usual to indicate these and other characteristic frequencies of stepper motors in Hertz full-step ("Hz FS"), i.e. full steps per second. The shaft of a stepper motor with a step angle of 1.8°, i.e. R = 200 full steps per motor revolution, which runs with e.g. 400 Hz FS, rotates with a speed of 2 revolutions per second or 120 revolutions per minute.

In order to reach speeds higher than the start-stop frequency, the stepper motor must be accelerated beyond this frequency with a suitable acceleration ramp, or be slowed down to a lower frequency with a suitable brake ramp. This acceleration or deceleration takes place by means of trapezoidal velocity-time profile. If necessary, damping (clean damper, installed at the second motor shaft end) is used in order to reach a higher rotary speed.

Nearly all standard stepper motors used by OWIS® are able to comply with a frequency of 400 Hz FS in start-stop operation mode.

The PS 10-32 has a digital profile generator. The speed profiles are periodically calculated and sent to the 2-phase stepper motor.

Cycle Time

The cycle duration of the digital profile generator is defined by hardware.

$$T_p = 256 \mu s$$

Final Velocity

The positioning of the axis is done by means of the "point-to-point" method. The axis follows a trapezoidal velocity profile.

The final velocity V after the acceleration ramp is specified by one 32-bit word. The value of V ranges from 1 to 2 147 483 647.

Note:
 It must be ensured that no higher velocity is entered than the equipment is able to withstand, since otherwise the mechanism may be damaged or destroyed.

When the speed V (without dimension) and the encoder line number R is given, the motor speed (without consideration of a gearbox!) is calculated as follows:

$$f_{Mcstp} = \frac{1}{s} \cdot V \quad (\text{step frequency in micro step mode})$$

respectively

$$f_{VS} = \frac{1}{s} \cdot \frac{V}{Mcstp} \quad (\text{step frequency normed for full step mode})$$

Note:
 A maximum frequency of $f_{VS, \max} = \frac{1}{T_p}$ can be set.

Herefrom, the motor rotary speed for a stepper motor (without consideration of a gearbox) with R full steps per motor revolution results to:

$$n_{RPM} = \frac{60}{\text{min}} \cdot \frac{V}{Mcstp \cdot R} \quad (\text{revolutions per minute})$$

respectively

$$n_{RPS} = \frac{1}{s} \cdot \frac{1}{Mcstp \cdot R} \quad (\text{revolutions per second})$$

For the conversion of the motor rotary speed to the positioning velocity of mechanism, mechanical data, such as spindle pitch, and, where appropriate, the influence of a gearbox, must also be taken into consideration.

Acceleration for Trapezoidal Velocity Profiling

The acceleration ("ACC") is specified by a 16-bit word.

The values of "ACC" range from 1 to 2 147 483 647.

When the velocity V and the acceleration ACC are given, the duration of trapezoidal profile acceleration ramp is calculated as follows:

$$\Delta t = 1 s \cdot \frac{V}{ACC} \quad (\text{acceleration/deceleration duration in seconds})$$

Travelled distance during the trapezoidal profile acceleration/ deceleration:

$$\Delta s = 1 Mcstp \cdot \frac{V^2}{2 \cdot ACC} \quad (\text{deceleration in microsteps})$$

10.2 DC Servo Motor

General Information

The PS 10-32 has a digital position/speed controller. Output and control

variables are periodically calculated. The acquisition of the actual position value is done in the simplest case by means of a rotary encoder (also just called an "encoder"), which is attached to the 2nd shaft extension of the motor. The most important parameter of the encoder is the number of encoder lines R. This is the number of the light/dark periods on the encoder disc for each motor shaft revolution. The signals go through a quad evaluation, which results in a generally 4-fold higher resolution than the number of encoder lines.

Servo Loop Cycle Time

The cycle duration of the digital controller is also called cycle time.

It is defined by hardware. The minimum cycle time is 204 μs.

If necessary, it can be increased:

$$T_s = (204, \dots, 20\,000) \mu s$$

Only integer values can be sent to the PS 10-32.

Default value (presetting): $T_s = 256 \mu s$

Final Velocity

The positioning of the axis is done by means of the "point-to-point" method. The axis follows alternatively a trapezoidal velocity profile.

The final speed V (without dimension) after acceleration ramp is specified by a 32-bit word. Its values range from 1 to 2 147 483 647.

Note:
 It must be ensured that no higher speed is entered than the equipment is able to withstand, otherwise the mechanism may be damaged or destroyed.

At a given speed V (dimensionless) and an encoder line number R , the motor speed (without consideration of a gearbox) is calculated as follows:

$$n = \frac{60}{\text{min}} \cdot \frac{V}{4R} \quad (\text{revolutions per minute})$$

respectively

$$n = \frac{1}{s} \cdot \frac{V}{4R} \quad (\text{revolutions per second})$$

respectively

$$n = \frac{1 \text{ increment}}{s} \cdot V \quad (\text{increments per second})$$

The last formula can be understood as:

The controller travels V increments each second.

For the conversion of motor rotary speed into positioning velocity of mechanics, mechanical data such as spindle pitch and, if appropriate, the influence of a gearbox have to be considered.

Example:

Positioning is to be effected at a rated speed of $n = 1800 \text{ rpm}$. An encoder with $R = 500$ lines is to be used.

What value of V should be selected?

Solution:

It results after resolving the equation for the speed of rotation:

$$V = \frac{n}{60} \cdot 4 \cdot R$$

Thus, $V = 60000$ for $n = 1800 \text{ rpm}$ when using a 500 line encoder. A spindle pitch of 1 mm gives a speed of 1.8 m/min or 30 mm/s then.

Acceleration for Trapezoidal Velocity Profiling

A 32-bit word is to be entered as acceleration ("ACC"), the values range from 1 to 2 147 483 647.

Duration of the trapezoidal profile acceleration ramp at given speed V and acceleration ACC :

$$\Delta t = 1 s \cdot \frac{V}{ACC} \quad (\text{acceleration/deceleration duration in seconds})$$

Travelled distance during the trapezoidal acceleration/ deceleration ramp:

$$\Delta s = 1 \text{ increment} \cdot \frac{V^2}{2 \cdot ACC} \quad (\text{deceleration in increments})$$

11. Initial Operation of the PS 10-32

11.1 Preparation of the Control Unit

Installation

The control is designed for simple control tasks in research and development as well as for industrial applications. It may only be operated in dry, dust-free environment. Normally, it is operated as a free-standing tabletop unit.

Note:
 Heat accumulation in the control should be avoided.

11.2 Connection of Peripherals and Devices

Before switching on the control, all connecting plugs for devices and peripherals have to be connected, so that they are recognized and initialized by the control during start-up.

This is:

- the positioning unit
- the power supply
- the computer

For a multipoint connection as well as:

- connecting cable for signal transfer with terminating connectors
- connecting cable for power supply (and alternatively one or further external desktop power supply)

The controller is connected via the USB interface to the computer.

For this, a driver installation is required. The driver is on the included CD.

For the installation please start "setup.exe".

Note:
 Any equipment and peripherals must be connected before the system starts, as otherwise it will not be recognized by the controller and will not be initialized.

11.3 System Start-up

When Windows is first started after the PS 10-32 has been connected, the operating system should recognize the new hardware. The driver can then be installed. In order to do this, administrator rights are necessary.

Initialization

After having switched on the power supply and activated the unit, the axis has to be initialized by the INIT command first. Axis parameters that have been changed will also be overwritten during the initialization.

Software

Following tools are included with purchase: the software tool OWISoft, the USB driver and the software interface (SDK/API) for C, C++, C#, LabView (V 8.2 and higher) and additional programming languages (32/64 bit). Thus, the PS 10-32 can be configured and operated comfortably

Supported operating systems: Windows XP, Windows Vista (32/64 bit), Windows 7 (32/64 bit), Windows 8 (32/64 bit), Windows 8.1 (32/64 bit) and Windows 10 (32/64 bit).

The software interface includes example programs with source code and help files.

When starting up using OWISoft, the respective parameters of the OWIS® positioning units are stored, and need only be selected.

Note:
 The stored parameters are for unloaded positioning. For optimum running the control parameters for the PID control loop have to be set for specific loads.

Please see the OWISoft user's guide, chapter 3.7.

For start up by a user application software the chapter "Instructions Concerning the Setup of User Application Software" follows. In addition, the command table for the PS 10-32 can be found.

CANopen-Networking

Activating a networked control unit is made by master/slave addressing (ID). The control connected via USB becomes automatically the master. The corresponding IDs to the control units are pre-configured and can be seen in the acceptance certification (see "Slave ID").

If a reassignment of a slave ID is necessary, please start the application "PS 10-32 CANconfig.exe" in the directory "..\OWISoft\Application\System".

To change an ID of the control unit it has to be connected as the master (via USB port, respectively) to the PC.

"Step 1" scans all slave IDs from 0-99 and detects the connected controls.

In "Step 2" the desired ID can be chosen and set by selecting the master slave ID.

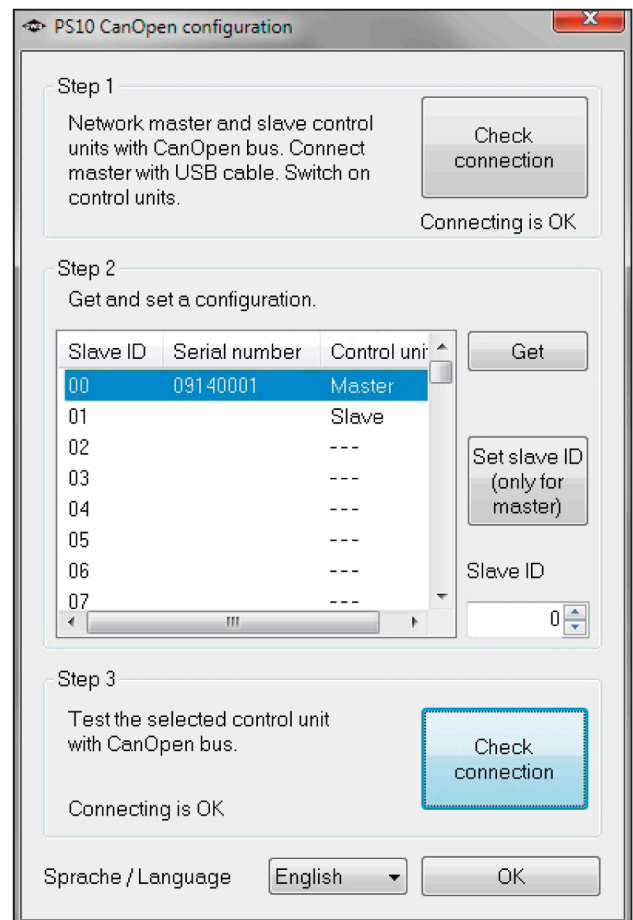

12. Malfunction Monitoring

12.1 Limit Switches

The PS 10-32 has four limit switch inputs, two for limit switches (MINSTOP, MAXSTOP) and two for brake switches (MINDEC, MAXDEC), as well as capability for a reference switch for each axis. One of the four limit switches is defined as reference switch.

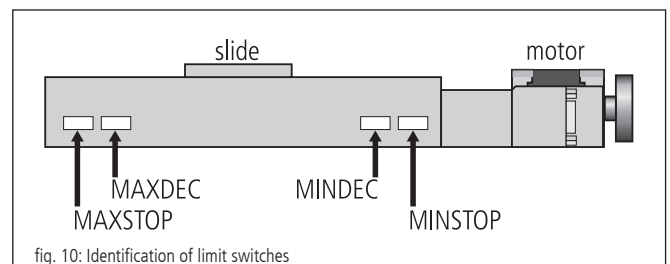
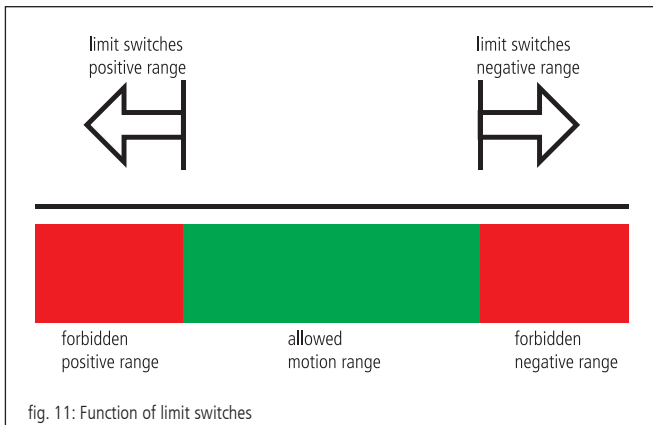

fig. 10: Identification of limit switches

OWIS® positioning units are provided with maximum of four limit switches. The limit switches working in negative direction (motion of the slide towards the motor) are named MINDEC and MINSTOP. The limit switches working in positive direction (motion of the slide away from the motor) are similarly named MAXDEC and MAXSTOP.



Working Principle of the Limit Switch Monitoring

1. **MINSTOP:** Actuation of this limit switch with motion in negative direction results in immediate disable of the motor power, after a certain reaction time which can be some milliseconds.
 DC servo motor: The motor is disabled. However, the residual kinetic energy leads to some remaining movement until it is used up by friction or stoppers.
 Step motor open loop: If the current travel frequency with which it is stopped was higher than the system start-stop frequency, the kinetic energy in the system leads to a remaining motion. This motion cannot be detected by the control unit, thus resulting in a wrongly indicated position. A reference travel is necessary to match the current position with the motor steps.
2. **MINDEC:** Actuation of this limit switch results in execution of a deceleration ramp, using a programmable deceleration value. After execution of the braking ramp, the motor will not be switched off but is still under control. If the follow up path of the deceleration ramp has been too big and the slide reached the MINSTOP limit switch afterwards, see 1.
3. **MAXDEC:** The reaction is similar to the MINDEC limit switch, but the effect is in positive direction.
4. **MAXSTOP:** The reaction is similar to the MINSTOP limit switch, but the effect is in positive direction.

Configuration of Limit and Reference Switches

The command "SMK..." defines which end switches should be used with the corresponding positioning units connected. If one bit is set (=1), the corresponding limit switch will be recognized.

The limit switch polarity is preset with the command "SPL...". The value handed over defines whether the limit or reference switches should be set to "low" or "high". A cleared bit means that the respective switch is "low" active (e.g., normally-open contact towards GND, which means "not connected" in inactive mode). If one bit is set (standard configuration), then the corresponding switch is "high" active (e.g., normally-open contact towards GND, which means "connected" in inactive mode).

The limit switch inputs work normally with 5V-CMOS-level, while NPN open-collector or push-pull outputs can also be connected, as high-impedance pull-up resistors (4.7 kOhm) towards +5V are already built-in.

Reconnection after Axis Error

When the axis error occurs after activating a limit switch (MINSTOP or MAXSTOP), the axis <n> should be released as follows:

1. Initialize via command:
INIT<n>
2. Release limit switch via command:
EFREE<n>

12.2 Output Stage Error Monitoring

The motor power stage is return its status. This signal is periodically monitored. If a power stage detects an error, then the motor is shut off, i.e. the control loop is opened and the power stage is disabled.

12.3 Time-Out Monitoring

Additionally, a timeout value (in ms, 32-bit range) can be defined as parameter for the axis. The monitoring can be switched off by setting the timeout to 0. This timeout is monitored periodically, while a motion is executed (PGO, REF, EFREE). If the motion lasts longer than this time, then the motor is shut off (?ASTAT → "Z", see command reverence, p. 43). This function is useful, if, for instance, during the reference motion one of the reference switches cannot be found.

13. Instructions Concerning the Setup of User Application Software

Generally, a PS 10-32 application consists of an initialization part which sets the necessary axis parameters for the axis <n> to be used, and which switches on the axis. Furthermore, it consists of a loop which executes a reference motion for the axis and of the actual user program with all the required functions.

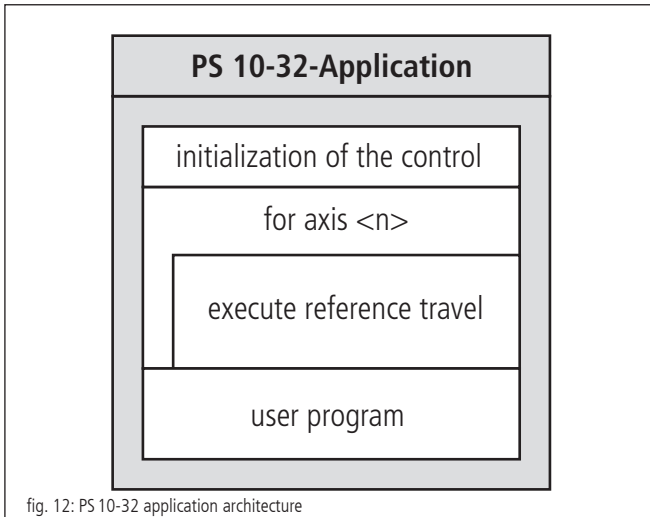

fig. 12: PS 10-32 application architecture

The simplest initialization of the required axis is done with the INIT command, if the parameters stored in the static RAM are to be used. Otherwise, it is necessary to transfer the necessary parameters, before sending the INIT command.

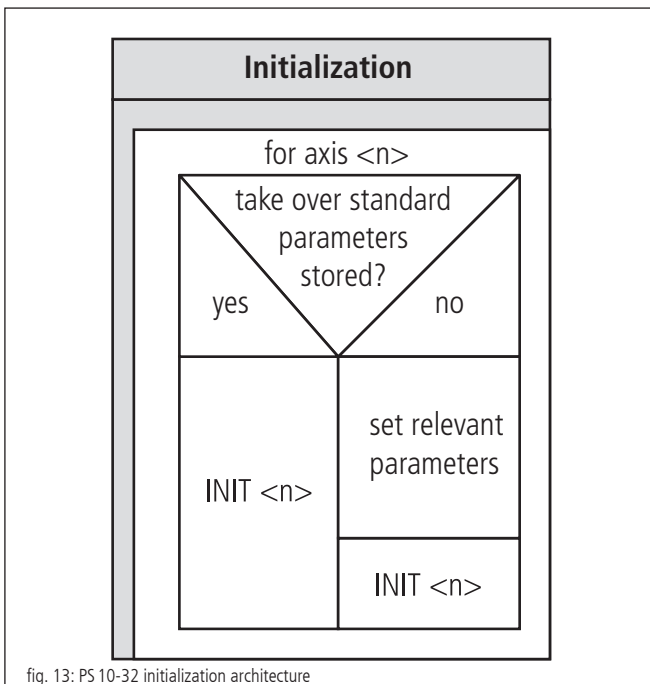

fig. 13: PS 10-32 initialization architecture

If a reference motion for the axis is to be executed, reference mask and reference polarity must be set before. This is necessary only if it has not already been done before, or if no appropriate values have been set for the standard settings. Then, the reference motion is started.

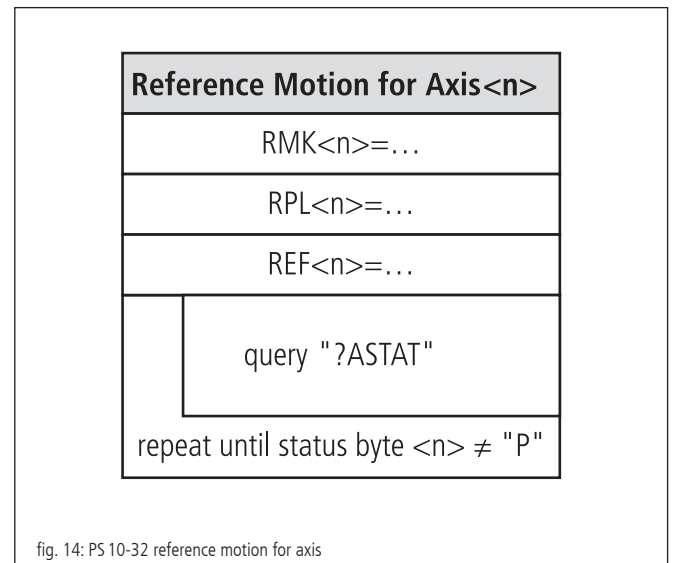

fig. 14: PS 10-32 reference motion for axis

A command processing time (interpretation time) of about 20 to 40 milliseconds has to be considered between two individual commands sent to the PS 10-32. The control unit signals received can be, for example, retrieved character by character every millisecond, until the defined end-of-string identifier is received.

The use of the provided software tool OWISoft (including SDK and DLL) facilitates the setup considerably, since frequently used command sequences are already recorded as functions or routines. Furthermore, the necessary running time check is implemented, too.

14. Command Set for the PS 10-32

General information concerning the command format:

Each command is transferred over the interface (USB) in ASCII format. The individual characters of a command are converted automatically into capital letters. Each command ends with CR or CR+LF or LF (adjustable). Furthermore, the response mode can be preset (TERM). For this purpose, there are three settings available:

- 1) When reading out the message buffer, only a two digit number is returned (error code). This setting is especially selected when a control takes place via software through a host PC, since the message strings are shortest, and therefore the command throughput is optimized.
- 2) Reading the message buffer returns a two digit number (error code) and an additional plain text string explaining the error code.
- 3) Similar to 2) and, additionally, each executed command giving no return value will be acknowledged with "OK".

Acknowledgment is returned with CR or CR + LF or LF (adjustable).

In the first response mode (TERM=0), the binary information (e.g. limit switch configuration, limit switch status, digital/analog inputs/outputs, etc.) is represented as bits of a decimal number. In the other modes (TERM=1, TERM=2) these values are indicated as binary number (one bit is represented by one ASCII character, "0" or "1").

All data in the RAM are deleted by switching off the control. At a restart the parameters are loaded from the EEPROM. Storing a changed configuration locally can be done by the command SAVEPARA.

For commands that give a response (e.g., parameter queries) the answer is sent back to the PC, immediately.

<n> = axis number = 1

<uv> = unsigned integer value

<sv> = signed integer value

14.1 CANopen-Networking

The protocol on the USB interface has been extended by the slave address. It is always put in front of the ASCII commands with two decimal places.

64?VERSION

64PVEL1 = 100000

01?VERSION

01PVEL1=100000

First, the PS 10-32 tests the slave address by the commands received via USB. If no slave address is placed in front, then the command is executed directly. Otherwise the own address is tested first. In case it is the own, then the command is executed directly, as well. Alternatively the command will be transformed and an access to the object directory of the corresponding PS 10-32 slave is executed by the CANopen protocol. The answer is retransferred and passed on from the master PS 10-32 to the computer.

The transfer rate of the CANopen bus is fix at 500kBit/s.

An existing USB connection specifies thereby the master or the slave operation on the CANopen side of the PS 10-32. If an USB connection exists, then this PS 10-32 behaves like a CANopen master or else the PS 10-32 behaves like a CANopen slave. Thus, only one PS 10-32 can be connected with the PC by USB when networking several ones together.

Note:

- Connecting and switching to another port of the PS 10-32 to the computer should only be done with unpowered control unit!

Attachment

I Command Table

command group	command	function description	example	response
general status request	?ASTAT	Axis state inquiry, a character for each axis is returned to describe the current axis mode: "I" = axis is not initialized "O" = axis is disabled "R" = axis initialized and ready "T" = axis is positioning in trapezoidal profile "V" = axis is operating in velocity mode "P" = reference motion is in progress "F" = axis is releasing a limit switch "L" = axis has been disabled after approaching a hardware limit switch (MINSTOP, MAXSTOP) "B" = axis has been stopped after approaching a brake switch (MINDEC, MAXDEC) "A" = axis has been disabled after limit switch error "M" = axis has been disabled after motion-controller error "Z" = axis has been disabled after timeout error "H" = phase initialization active (step motor axis) "U" = axis not enabled "E" = axis has been disabled after motion error "?" = error, unknown state of axis	?ASTAT	I IORRTTJV
	?MSG	Read out the message exit buffer, the message exit buffer is used only for error messages, which concern the command interface (wrong command, missing parameters, invalid value). Possible messages are: "00 NO MESSAGE AVAILABLE" (will be returned after the attempt to read out the message buffer, even though no message is currently present) "01 PARAMETER BEFORE EQUAL WRONG" (will be written into the message buffer, if the command interpreter has failed to convert the parameter before the equals sign into a number correctly) "02 AXIS NUMBER WRONG" (will be written into the message buffer, if the command interpreter has failed to evaluate the given axis number correctly; valid: 1) "03 PARAMETER AFTER EQUAL WRONG" (will be written into the message buffer, if the command interpreter has failed to convert the parameter after the equals sign into a number correctly) "04 PARAMETER AFTER EQUAL RANGE" (will be written into the message buffer, if the command interpreter has recognized that the parameter after the equals sign is beyond its valid range) "05 WRONG COMMAND ERROR" (will be written into the message buffer, if a syntax error has occurred, i.e., the command interpreter has not been able to recognize the given command) "06 REPLY IMPOSSIBLE" (will be returned, if the reply could not be transferred to the host, because the output buffer is not yet empty, e.g.) "07 AXIS IS IN WRONG STATE" (will be written into the message buffer, if a positioning command or a configuration parameter has been sent that could not be recognized because the axis is currently in a different motion state)	?MSG	00 NO MESSAGE...
	?ESTAT<n>	Read out current logical state of the limit switches and power stage feedback for the axis: Bit 0 = MINSTOP Bit 1 = MINDEC Bit 2 = MAXDEC Bit 3 = MAXSTOP Bit 4 = motor power-stage error	?ESTAT1	10101
	?ERR	Error query from the error memory with a memory depth of 20. The error number is always returned as number with four digits. Based on the error code its cause can be determined. If the returned value is 0, there are no further error messages stored.	?ERR	1211
	?EMERGINP	Returns current state of emergency-stop.	?EMERGINP	1

command group	command	function description	example	response
general status request	?READOWID<n>	Read out memory contents of ONE-Wire-Chip from positioning unit until 0x00 limit detection and data transfer to the PC. As parameter the initial address 0x00 up to 0x70 will be passed in the ONE-Wire-Chip. From this Address max. 16 bytes will be detected or it will be read until the end recognition.	?READOWID1=0	INFO1 INFO2
	?READOWUB<n>	Read out memory contents of ONE-Wire-Chip from address 0x86 and 0x87 (=UserBytes) in the positioning unit and transmission of data to the PC.	?READOWUB1	10
base configuration	MOTYPE<n>=<uv>	Set motor type for the axis: 0 = DC brush 1 = stepper motor Open Loop	MOTYPE1=0	
	?MOTYPE<n>	Read out motor type for the axis.	?MOTYPE1	0
	AMPSHNT<n>=<uv>	Set current range for axis: 0 = current range 1 (low) 1 = current range 2 (high)	AMPSHNT1=0	
	?AMPSHNT<n>	Query current range for axis.	?AMPSHNT1	0
	TERM=<uv>	Set terminal mode: mode 0 = short response mode 1 = response with plain text mode 2 = response with plain text and "OK" handshake after each command without feedback	TERM=2	
	?TERM	Query terminal mode.	?TERM	2
	BAUDRATE=<uv>	Set baud rate for the serial interface, allowed values: 9600, 19200, 38400, 57600, 115200 This setting becomes active only after the next reset or power-on.	BAUDRATE=9600	
	?BAUDRATE	Query current baud rate for the serial interface.	?BAUDRATE	9600
	COMEND=<uv>	Set command end identification: 0 = CR 1 = CR+LF 2 = LF	COMEND=0	
	?COMEND	Read out command end identification.	?COMEND	0
	?SERNUM	Query serial number of the PS 10-32.	?SERNUM	09080145
	SAVEPARA	Save global- and axis parameters to EEPROM. This command has to be sent when the configuration has changed to save the modification locally.	SAVEPARA	
	?VERSION	Read out software version of the firmware installed on the main board.	?VERSION	PS10-V3.0-181010
	?POSERR<n>	Read out current position error for the axis. The difference between encoder position and default position is returned.	?POSERR1	-15
	?MXSTROKE<n>	Read out measured travel. This command reads out the travel ascertained by referencing in mode 6 and 7.	?MXSTROKE1	340000
	?AMPST<n>	Query state of the axis. Bit 0 = temperature error for the axis Bit 1 = error for axis because of emergency-stop is switched off Bit 2 = error by reading a wrong motor code Bit 3 = error by activated short-circuit protection	?AMPST1	0
	AMPMODE<n>	Set state for the axis. With this command the type of quick de-excitation for the axis can be set: Bit 0 and Bit 1 = type of de-excitation for the chopper 00:slow, 01:15% mixed, 10:48% mixed, 11:fast Bit 2 = blanking-time 0 = short, 1 = long Bit 3 = Ext. Mode, de-excitation when enable to low 0 = fast, 1 = slow Bit 4 = Enable, withdraws current at zero crossing Bit 5 = inverts rotational direction for stepper motor	AMPMODE1	
	?AMPMODE<n>	Query mode for axis.	?AMPMODE1	3
	SLAVEID=<uv>	Set Slave-ID for CAN-Daisy-Chain, 00 to 99.	SLAVEID=64	
	?SLAVEID	Query Slave-ID.	?SLAVEID	64
RESETMB	Release reset main board.	RESETMB		
ERRCLEAR	Clear error memory.	ERRCLEAR		

command group	command	function description	example	response
positioning operation	INIT<n>	Enable the motor power stage, release and activate position control loop. With this command, the axis is initialized completely, the motor is powered and the position control feedback loop is active. This command must be transferred after switching-on the PS 10-32, so that the axis can be taken into operation, using the commands REF, PGO, VGO, etc. Before this, the following parameters must have been preset: motor type, limit switch mask and polarity, feedback control loop parameters, current range of the motor output stage. Resets the power stages short-circuit protection.	INIT1	
	PSET<n>=<sv>	Set target position respectively relative travel distance (ABSOL/RELAT) for the axis. If absolute position format is switched on, then the parameter is interpreted as signed absolute position; if relative position indication is chosen, then the parameter is interpreted as signed travel distance. The new absolute target position is the sum of last absolute target position and transferred travel.	PSET1=100000	
	?PSET<n>	Read out target position respectively relative travel distance for the axis.	?PVEL1	10000
	VVEL<n>=<sv>	Set target speed for velocity mode for the axis. With this command, the start speed is transmitted, while the axis moves in the velocity mode.	VVEL1=-20000	
	?VVEL<n>	Read out target speed for velocity mode.	?VVEL1	-20000
	PGO<n>	Start positioning for the axis. The axis approaches the new target position in trapezoidal mode.	PGO1	
	VGO<n>	Start velocity mode for the axis.	VGO1	
	STOP<n>	Stop motion of the axis. Any active motion command for the axis is interrupted. The drive decelerates with the preset ramp parameters and halts..	STOP1	
	VSTP<n>	Stop velocity mode for the axis. If the axis is in the velocity mode, this command will terminate this mode and stop the axis.	VSTP1	
	EFREE<n>	Release limit switch(es) of the axis. After a drive has moved onto a limit switch (MINSTOP, MAXSTOP) or brake switch (MINDEC, MAXDEC), the active switch(es) can be released using this command. The direction of the movement is automatically decided according to whether a positive or negative limit or break switch is activated.	EFREE1	
	MON<n>	Enable the motor power stage and activate position control feedback loop. With this command, the axis that has been switched off previously (by means of the "MOFF" command) can be switched on again. Position control loop and the enable input for the power stage are activated.	MON1	
	MOFF<n>	Disable the motor power stage and deactivate position control feedback loop. With this command, position control loop and the enable input for the power stage are deactivated. The motor is switched off.	MOFF1	
	CNT<n>=<sv>	Set current position counter for the axis.	CNT1=5000	
	?CNT<n>	Read out current position counter for the axis.	?CNT1	5000
	CRES<n>	Reset current position counter for the axis.	CRES1	
	?VACT<n>	Read out current speed for the axis.	?VACT1	10000
?ENCPOS<n>	Read out current encoder position counter for the axis. This command provides the current encoder position for an open-loop stepper motor, run with an encoder.	?ENCPOS1	5000	
positioning parameters	RELAT<n>	Set entry mode of coordinates for the axis to "relative" (= indication of the signed travel distance).	RELAT1	
	ABSOL<n>	Set entry mode of coordinates for the axis to "absolute" (= indication of the signed target position).	ABSOL1	
	?MODE<n>	Query the active/current entry mode of coordinates for the axis.	?MODE1	ABSOL
	PVEL<n>=<uv>	Set maximum positioning velocity for the axis. Used for the trapezoidal profile.	PVEL1=10000	
	?PVEL<n>	Read out maximum positioning velocity for the axis.	?PVEL1	10000
	FVEL<n>=<uv>	Set limit switch release speed for the axis (unsigned value).	FVEL1=1000	
	?FVEL<n>	Read out limit switch release speed for the axis.	?FVEL1	1000
	ACC<n>=<uv>	Set acceleration (= run-up ramp) for the axis. Used for all modi (trapezoidal, velocity mode, etc.).	ACC1=300000	
?ACC<n>	Read out acceleration for the axis.	?ACC1	300000	

command group	command	function description	example	response
axis parameters	MCSTP<n>=<uv>	Set micro step resolution with the stepper motor axis.	MCSTP1=50	
	?MCSTP<n>	Read out micro step resolution with the stepper motor axis.	?MCSTP1	50
	DRICUR<n>=<uv>	Set driving current with stepper motors in percent of the maximum output value defined by the selected current range of the motor power stage.	DRICUR1=50	
	?DRICUR<n>	Read out driving current with stepper motors in percent.	?DRICUR1	50
	HOLCUR<n>=<uv>	Set holding current with stepper motor axes in percent.	HOLCUR1=30	
	?HOLCUR<n>	Read out holding current with stepper motor axis in percent.	?HOLCUR1	30
	ATOT<n>=<uv>	Set timeout in milliseconds, 0 switches off the timeout monitoring.	ATOT1=20000	
	?ATOT<n>	Query time-out for the axis.	?ATOT1	20000
	FKP<n>=<uv>	Set control parameter KP for the axis.	FKP1=25	
	?FKP<n>	Query control parameter KP for the axis.	?FKP1	25
	FKD<n>=<uv>	Set control parameter KD for the axis.	FKD1=5	
	?FKD<n>	Query control parameter KD for the axis.	?FKD1	5
	FKI<n>=<uv>	Set control parameter KI for the axis.	FKI1=10	
	?FKI<n>	Query control parameter KI for the axis.	?FKI1	10
	FIL<n>=<uv>	Set control parameter integration limit for the axis.	FIL1=100000	
	?FIL<n>	Query control parameter integration limit for the axis.	?FIL1	100000
	FST<n>=<uv>	Set sample time for the axis (in micro seconds).	FST1=500	
	?FST<n>	Query sample time for the axis (in micro seconds).	?FST1	500
	FDT<n>=<uv>	Set delay time of the differential term (KD) for the axis (in sample time cycles).	FDT1=5	
	?FDT<n>	Query delay time of the differential term (KD) for the axis (in sample time cycles).	?FDT1	5
	MXPOSERR<n>=<uv>	Sets maximum positioning error for an axis. When this limit is exceeded the axis is switched off. This shut-off is only valid for the DC motor type.	MXPOSERR1=50	
	?MXPOSERR<n>	Read out maximum positioning error for an axis.	?MXPOSERR1	50
	MAXOUT<n>=<uv>	Set maximum output value for the servo loop in percent. With this command, the maximum value for the axis to be returned at the servo amplifier can be set. Maximum value allowed: 99%.	MAXOUT1=95	
	?MAXOUT<n>	Read out maximum output value in percent.	?MAXOUT1	95
AMPPWMF<n>=<uv>	Set PWM output frequency of drive controller board, 20000 or 80000 is possible.	AMPPWMF1=20000		
?AMPPWMF<n>	Query PWM frequency of drive controller board.	?AMPPWMF1	20000	
PHINTIM<n>=<uv>	Set phase initialization time in multiples of the cycle time.	PHINTIM1=10		
?PHINTIM<n>	Read out phase initialization time in multiples of the cycle time.	?PHINTIM1	10	

command group	command	function description	example	response
limit switch configuration and reference travel	REF<n>=<uv>	Start reference travel while indicating the reference mode for the axis: mode 0 = search next index impulse and stop mode 1 = approach reference switch and stop mode 2 = approach reference switch, search next index impulse and stop mode 3 = mode 0, additionally set act. position to 0 mode 4 = mode 1, additionally set act. position to 0 mode 5 = mode 2, additionally set act. position to 0 mode 6 = approach maximum reference switch, approach minimum reference switch, set current position to 0 mode 7 = approach minimum reference switch, approach maximum reference switch, set current position to 0	REF1=4	
	RVELS<n>=<sv>	Set reference travel speed "slow" for the axis. Using this speed, the index pulse will be searched or the reference switch will be released, respectively (signed value).	RVELS1= 2000	
	?RVELS<n>	Read out reference travel speed „slow“ for the axis.	?RVELS1	2000
	RVELF<n>=<sv>	Set reference travel speed „fast“ for the axis. The drive moves with this speed towards the limit switch (signed value).	RVELF1= -20000	
	?RVELF<n>	Read out reference travel speed „fast“ for the axis.	?RVELF1	-20000
	RDACC<n>=<uv>	Set reference travel deceleration for the axis. This value is used when the reference point is approached.	RDACC1 =300000	
	?RDACC<n>	Read out reference travel deceleration for the axis.	?RDACC1	300000
	SMK<n>=<uv>	Set limit switch mask for the axis. This command activates or deactivates the limit and break switches. If a limit switch is approached, the movement is stopped abruptly and the motor is shut off. Bit sequence : <MAXSTOP, MAXDEC, MINDEC, MINSTOP>.	SMK1=0110	
	?SMK<n>	Read out limit switch mask for the axis.	?SMK1	0110
	SPL<n>=<uv>	Set limit switch polarity for the axis. With this command, the active level for the limit and brake switches is defined. Bit sequence: <MAXSTOP, MAXDEC, MINDEC, MINSTOP>.	SPL1=1111	
	?SPL<n>	Read out limit switch polarity for the axis.	?SPL1	1111
	RMK<n>=<uv>	Set reference switch mask for the axis. With this command, it can be defined which of the 4 limit switches for the axis should be interpreted as reference switch. A mask with exactly one character "1" has to be transferred. Bit sequence: <MAXSTOP, MAXDEC, MINDEC, MINSTOP>.	RMK1=0001	
	?RMK<n>	Read out reference switch mask for one axis.	?RMK1	0001
	RPL<n>=<uv>	Set reference switch polarity for one axis. This command defines the active level of the reference switch. Bit sequence: <MAXSTOP, MAXDEC, MINDEC, MINSTOP>.	RPL1=1110	
	?RPL<n>	Read out reference switch polarity for one axis.	?RPL1	1110
	?HYST<n>	Read out reference switch hysteresis for the axis. After a reference motion has been terminated successfully, the hysteresis of the switch can be read out with this command. (The value is correct only, if none of the reference/limit switches is active any more)	?HYST1	28
	?REFST<n>	Inquiry of reference motion validity. When reference motion successfully completed, the state is set on 1 = "valid". If a motor without encoder is switched off (e.g. open-loop stepper), then the validity is reset to 0.	?REFST1	1
	LMK<n>=<uv>	Set mask for limit-positioning monitoring for the axis. With this command the limit-positioning monitoring for the lower limit and/or upper limit for position can be set active and inactive, respectively. The limit-positioning monitoring behaves like the according DEC-switch. Bit sequence: <MAXDEC, MINDEC>.	LMK1=01	
	?LMK<n>	Read out limit-positioning monitoring mask for axis	?LMK1	01
	?LSTAT<n>	Read current, logical state of limit-positioning monitoring for the axis. Bit 0 = MINDEC lower limit is transcended Bit 1 = MAXDEC upper limit is transcended	?LSTAT1	01
SLMIN<n>=<uv>	Set negative limit position for the axis.	SLMIN1=100		
?SLMIN<n>	Read out negative limit position for the axis.	?SLMIN1	100	
SLMAX<n>=<uv>	Set positive limit position for the axis.	SLMAX1=100000		
?SLMAX<n>	Read out positive limit position for the axis.	?SLMAX1	100000	

command group	command	function description	example	response
in-/outputs ¹⁾	?INPUTS	Read out state of inputs (4-bit binary number).	?INPUTS	0010
	OUTPUT<uv>=<uv>	Change current state of an output.	OUTPUT1=0	
	?OUTPUTS	Read out current state of all outputs.	?OUTPUTS	00101
	OUTMODE=<uv>	Set output operating mode for the outputs Out1 and Out2. These outputs can either be driven as a digital or as PWM output, alternatively. output modus = 0 : OUT1 and OUT2 digital outputs output modus = 1 : OUT1 digital output, OUT2 PWM output output modus = 2 : OUT1 and OUT2 PWM outputs	OUTMODE=1	
	?OUTMODE	Read out output operating mode for outputs Out1 and Out2.	?OUTMODE	1
	?ANIN<uv>	Query analog input. The port number from 1 to 4 will be set, and the converted 10-bit value will be returned.	?ANIN3	234
	OPWM<uv>=<uv>	Set PWM output, the port number from 1 to 2 and the level control value are set from 0 to 100 %.	OPWM1=55	
	?OPWM<uv>	Query PWM output. The port number from 1 to 2 is entered and the level control value that has been set is returned from 0 to 100 %.	?OPWM1	55
holding brake control	HBCH<n>=<uv>	Assign PWM output for holding brake to the axis: <AxisNumber> = <PWM port> PWM port = 0 for holding break function off	HBCH1=1	
	?HBCH<n>	Query holding brake assignment PWM port to the axis.	?HBCH1	1
	HBFV<n>=<uv>	Set first PWM value to activate the holding brake: <AxisNumber> = <Percent Value>.	HBFV1=50	
	?HBFV<n>	Query first PWM value for activation of the holding brake.	?HBFV1	50
	HBSV<n>=<uv>	Set second PWM value for clamping the holding brake: <AxisNumber> = <Percent Value>.	HBSV1=20	
	?HBSV<n>	Query second PWM value for clamping the holding brake.	?HBSV1	20
	HBTI<n>=<uv>	Set settling time for the holding brake. The first PWM value will be set for this amount of time after activation of the holding brake: <AxisNumber> = <Time for first PWM value in ms>.	HBTI1=300	
?HBTI<n>	Query settling time for the holding brake. The first PWM value will be set for this amount of time after activation of the holding brake.	?HBTI1	300	

¹⁾ The pins which have to be addressed with <uv> on the I/O connector can be taken in the connecting table (attachement III).

II Relevance of the Parameters for different Motor Types

parameter	DC brush	2-phase step motor open-loop
MOTYPE	+	+
FKP	+	-
FKD	+	-
FDT	+	-
FKI	+	-
FIL	+	-
FST	+	-
MAXOUT	+	+ ¹⁾
SMK	+	+
SPL	+	+
RMK	+	+
RPL	+	+
RVELF	+	+
RVELS	+	+
ACC	+	+
PVEL	+	+
FVEL	+	+
ABSOL	+	+
RELAT	+	+
AMPPWMF	+	+
MCSTP	-	+
DRICUR	+	+
HOLCUR	-	+
AMPSHNT	+	+
PHINTIM	-	+
ATOT	+	+
HBCH	(+)	(+)
HBFV	(+)	(+)
HBTI	(+)	(+)
HBSV	(+)	(+)

+ necessary
 - not necessary
 (+) optional

¹⁾ The command may be used, however, it is important that the value set here is larger than or equal to the maximum PWM value for DRICUR or HOLCUR. In any case, the output is limited to the value defined by MAXOUT. If a too small value is selected, the micro-step operation will not work properly.

III Connecting Table

In-/Outputs

Pin assignment of the 25-pin D-Sub male connector:

function	pin
Analog input 1	6
Analog input 2	5
Analog input 3	4
Analog input 4	3
TTL input 1	10
TTL input 2	9
TTL input 3	8
TTL input 4	7
SPS output 1	16
SPS output 2	15
SPS output 3	14
SPS output 4	13
TTL output 5	17
+5V, max. 300 mA total current	1, 2
PWM output 1, max. 1 A	20
PWM output 2, max. 1 A	21
+24V, max. 1 A total current	18, 19
GND	11, 12, 24, 25
enable input + (5V) *)	22
enable input - (GND)	23

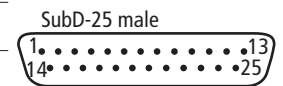

*) enable motor output stage over optoelectronic coupler ($U_B = 5V$) necessary;
 e.g. jumper pin 2 → pin 22 and pin 23 → pin 24

BUS System

Pin assignment of the 9-pin D-Sub connector:

function	pin
GND	3, 6
CAN-H	7
CAN-L	2

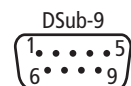

Universal Motor Connector

Pin assignment of the 37-pin D-Sub female connector:

	pin	DC motor	stepper motor OL
performance	19	motor +	phase 1 +
	18	motor -	phase 1 -
	17	motor +	phase 2 +
	16	motor -	phase 2 -

signals	15	motor type encoding
	14	motor type encoding
	13	GND
	12	+5V
	11	encoder A
	10	encoder \bar{A}
	9	encoder B
	8	encoder \bar{B}
	7	encoder Index
6	encoder $\bar{\text{Index}}$	

switches + signals	5	MINSTOP
	4	MINDEC
	3	MAXDEC
	2	MAXSTOP
	1	GND
	37	motor holding brake +24V
	36	motor holding brake -
	35	(reserved)
	34	(reserved)
	33	(reserved)
	32	(reserved)
	31	GND
	30	+5V
	29	OWISid
	28	(reserved)
	27	(reserved)
	26	(reserved)
	25	(reserved)
	24	(reserved)
	23	(reserved)
	22	+5V
	21	GND
	20	+24V

EU/UE Konformitätserklärung/Declaration of conformity

Wir
We

OWIS GmbH
Im Gaisgraben 7
79219 Staufen / Germany
+49(0)7633/9504-0
+49(0)7633/9504-440
www.owis.eu
info@owis.eu

erklären in alleiniger Verantwortung, dass das Produkt
declare under our sole responsibility that the product

PS 10-32

auf das sich diese Erklärung bezieht, mit den folgenden Normen oder normativen Dokumenten übereinstimmt.
to which this declaration relates is in conformity with the following standards or other normative documents.

EN 61000-6-1:2007 mit/with EN 61000-4-2:2009, EN 61000-4-3:2011
EN 61000-6-3:2011 mit/with EN 55014-1:2012

Gemäss den Bestimmungen der Richtlinie:
Following the provisions of directive:

2014/30/EU

Ort und Datum der Ausstellung
Place and date of issue

Staufen, 27.09.2017

Name und Unterschrift
Name and signature

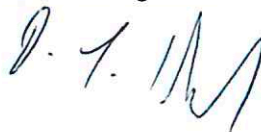

D. J. Schuhen
Leitung Vertrieb



i.A. Dr. Peter Hilgers
Leitung Entwicklung

